

Bonewall

Technics Book

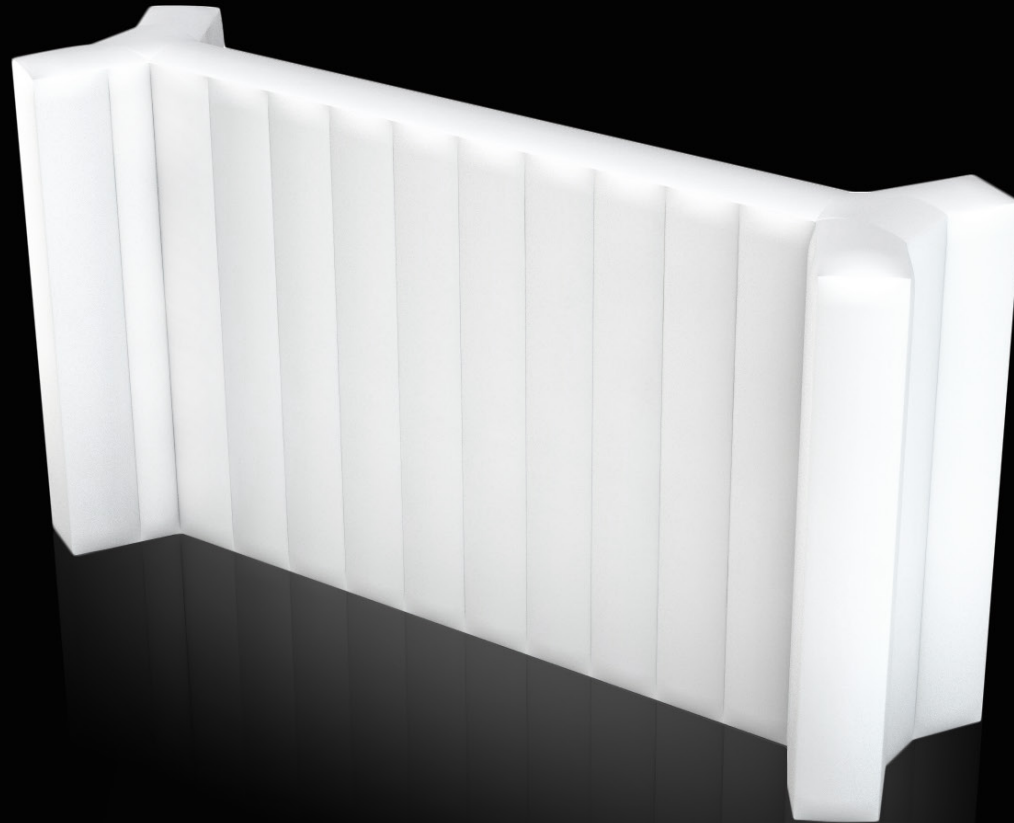

October 2014

Designed in England | Made in the Future

IS-002-01 Bonewall3m

Core Package

• 1 x Structure, 1 x Packing Bag, 1 x Core 125 Fan, 1 x User Manual

Structure

INFLATED EXTERNAL FOOTPRINT: • 5.28 m²

FABRICS: • FR treated rip-stop nylon.

Power and Fans

FANS: • 1 x Core 125 Fans

POWER DRAWN: • 0.17 amp

FAN DIMENSIONS: • 0.36 m x 0.36 m x 0.36 m (boxed)

NOTE: It is the responsibility of the client (unless agreed otherwise) or site management to ensure that the power used for fans is secure and tested. The above power consumption is for fans only and covers no extra electrical items. No other item should be connected to the fans power lines. Inflate accepts no responsibility for damages to equipment or damages to inflatable structures, injuries to persons, or loss of earnings due to electrical power faults. All fans have 0.3 m 13 amp plug unless otherwise requested. All fans run on 220 Volt standard. For other power levels please consult with Inflate at time of order/enquiry.

Estimated Shipping Weight

ESTIMATED PACKED SIZE: • 1 x Packing Bag of 0.5 m x 0.5 m x 0.3 m

STRUCTURE WEIGHT: • Gross 7 Kgs

FAN WEIGHT: • 3 kgs per fan.

TOTAL WEIGHT: • 10 kgs + package

Installation and Derig

CREW: • min. 1 person

SET UP TIME: • From 5 mins

INFLATION TIME: • 3 mins for structure when fixed

DERIG TIME: • From 5 mins

NOTE: The above refers to setting up the structures and inflation only. Minimums given are to achieve secure installation. Times may vary due to on site location factors, lack of access and other elements outside of Inflates control. Inflate accepts no responsibility for damages to equipment or damages to inflatable structures, injuries to persons, or loss of earnings due to incorrect structure installation method.

NOTE: Please refer to attached technical drawings for specific details on structure and accessory positions. Please note this information is given as guidance only. Inflate accept no responsibility for variations in dimensions or weights.

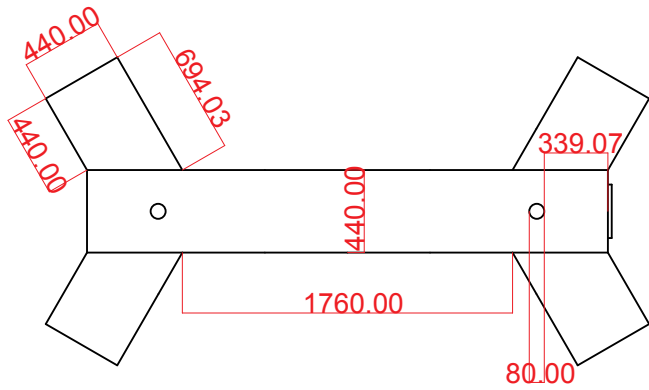

Plan View

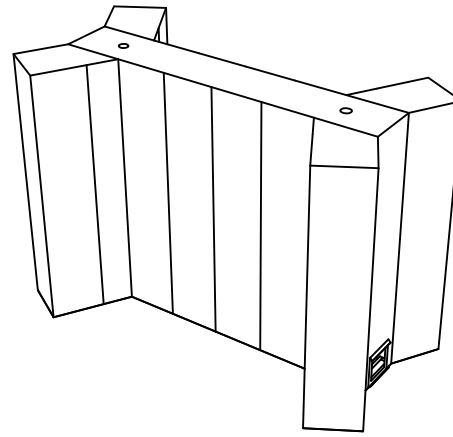

Perspective

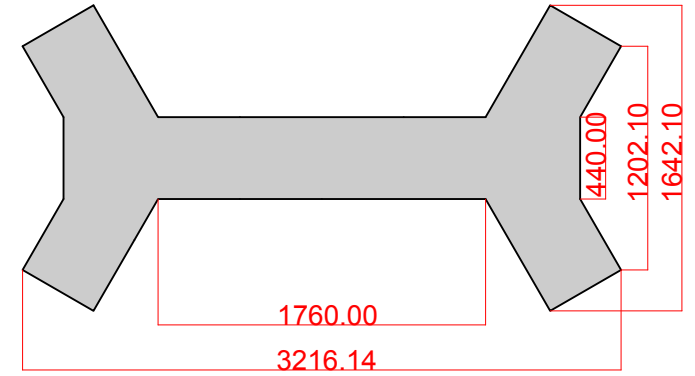

Footprint

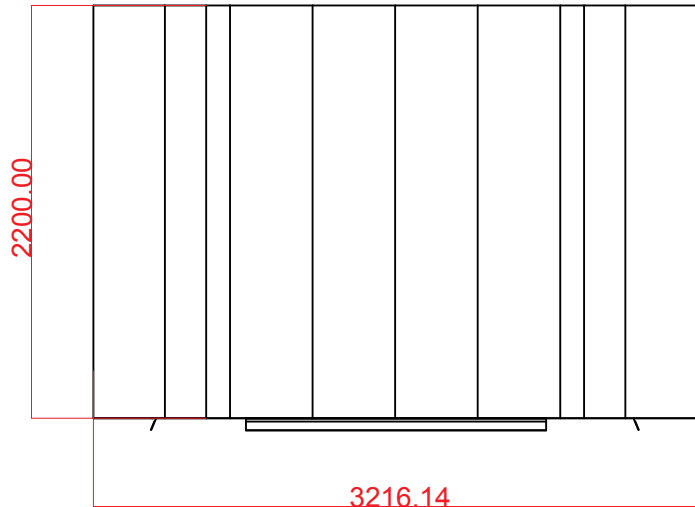

Front View

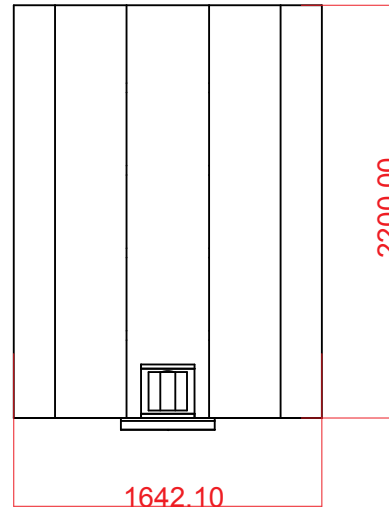

Side View

IS-002-02 Bonewall4m

Core Package

• 1 x Structure, 1 x Packing Bag, 1 x Core 125 Fan, 1 x User Manual

Structure

INFLATED EXTERNAL FOOTPRINT: • 6.7 m²

FABRICS: • FR treated rip-stop nylon.

Power and Fans

FANS: • 1 x Core 125 Fans

POWER DRAWN: • 0.17 amp

FAN DIMENSIONS: • 0.36 m x 0.36 m x 0.36 m (boxed)

NOTE: It is the responsibility of the client (unless agreed otherwise) or site management to ensure that the power used for fans is secure and tested. The above power consumption is for fans only and covers no extra electrical items. No other item should be connected to the fans power lines. Inflate accepts no responsibility for damages to equipment or damages to inflatable structures, injuries to persons, or loss of earnings due to electrical power faults. All fans have 0.3 m 13 amp plug unless otherwise requested. All fans run on 220 Volt standard. For other power levels please consult with Inflate at time of order/enquiry.

Packed Structure

ESTIMATED PACKED SIZE: • 1 x Packing Bag of 0.6 m x 0.5 m x 0.4 m

STRUCTURE WEIGHT: • Gross 8 Kgs

FAN WEIGHT: • 3 kgs

TOTAL WEIGHT: • 11 kgs + package

Installation and Derig

CREW: • min. 1 person

SET UP TIME: • From 5 mins

INFLATION TIME: • 3 mins for structure when fixed

DERIG TIME: • From 5 mins

NOTE: The above refers to setting up the structures and inflation only. Minimums given are to achieve secure installation. Times may vary due to on site location factors, lack of access and other elements outside of Inflates control. Inflate accepts no responsibility for damages to equipment or damages to inflatable structures, injuries to persons, or loss of earnings due to incorrect structure installation method.

NOTE: Please refer to attached technical drawings for specific details on structure and accessory positions. Please note this information is given as guidance only. Inflate accept no responsibility for variations in dimensions or weights.

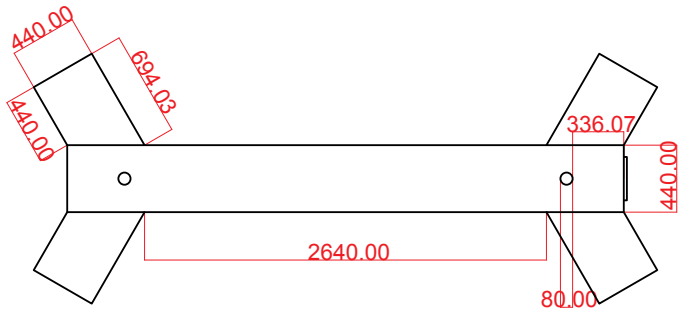

Plan View

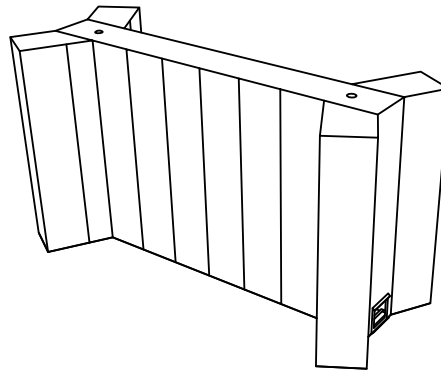

Perspective

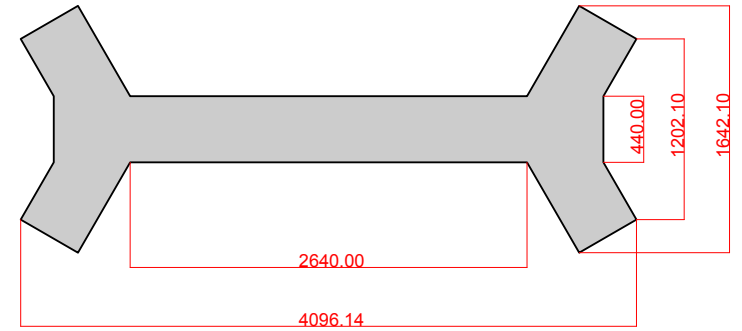

Footprint

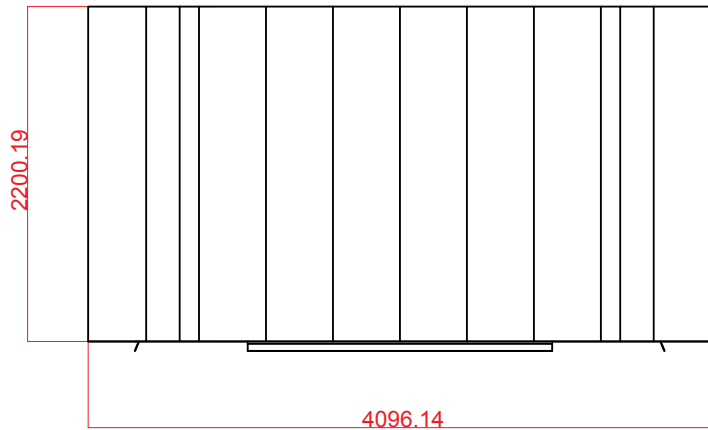

Front View

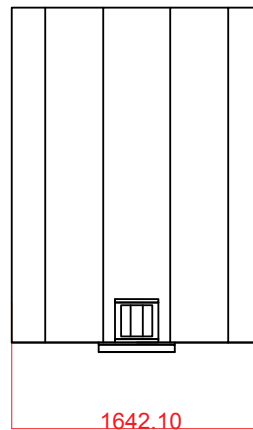

Side View

General Arrangement Drawings

Bonewall4m

Designed in England | Made in the Future

IS-002-03 Bonewall5m

Core Package

• 1 x Structure, 1 x Packing Bag, 1 x Core 125 Fan, 1 x User Manual

Structure

INFLATED EXTERNAL FOOTPRINT: • 8.1 m²

FABRICS: • FR treated rip-stop nylon.

GROUND FIXINGS: • Refer to engineering guidance notes

Power and Fans

FANS: • 1 x Core 125 Fans

POWER DRAWN: • 0.17 amp

FAN DIMENSIONS: • 0.36 m x 0.36 m x 0.36 m (boxed)

NOTE: It is the responsibility of the client (unless agreed otherwise) or site management to ensure that the power used for fans is secure and tested. The above power consumption is for fans only and covers no extra electrical items. No other item should be connected to the fans power lines. Inflate accepts no responsibility for damages to equipment or damages to inflatable structures, injuries to persons, or loss of earnings due to electrical power faults. All fans have 0.3 m 13 amp plug unless otherwise requested. All fans run on 220 Volt standard. For other power levels please consult with Inflate at time of order/enquiry.

Packed Structure

ESTIMATED PACKED SIZE: • 1 x Packing Bag of 0.7 m x 0.6 m x 0.5 m

STRUCTURE WEIGHT: • Gross 9 Kgs

FAN WEIGHT: • 3 kgs per fan.

TOTAL WEIGHT: • 12 kgs + package

Installation and Derig

CREW: • min. 1 person

SET UP TIME: • From 5 mins

INFLATION TIME: • 3 mins for structure when fixed

DERIG TIME: • From 5 mins

NOTE: The above refers to setting up the structures and inflation only. Minimums given are to achieve secure installation. Times may vary due to on site location factors, lack of access and other elements outside of Inflates control. Inflate accepts no responsibility for damages to equipment or damages to inflatable structures, injuries to persons, or loss of earnings due to incorrect structure installation method.

NOTE: Please refer to attached technical drawings for specific details on structure and accessory positions. Please note this information is given as guidance only. Inflate accept no responsibility for variations in dimensions or weights.

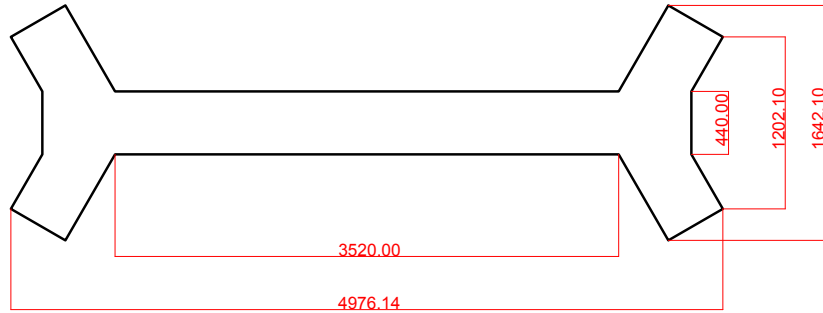

Plan View

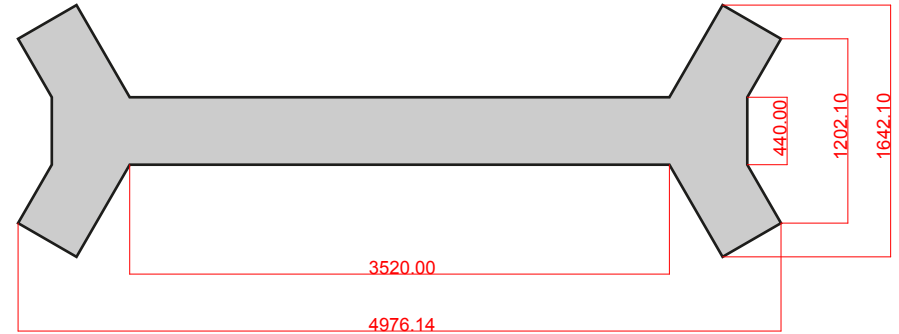

Footprint

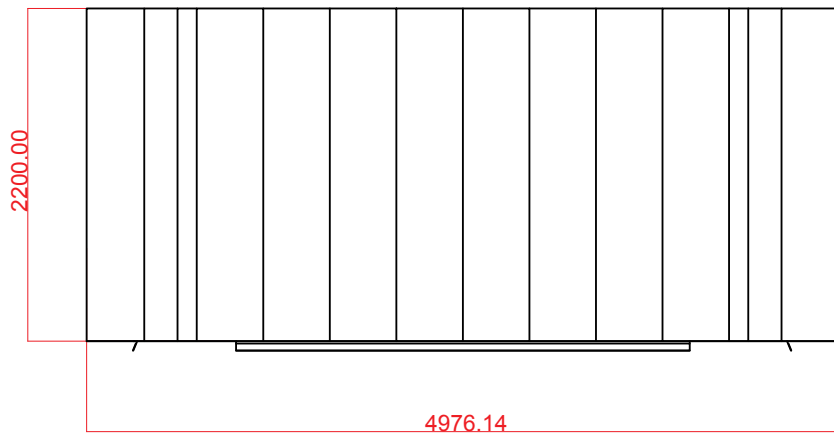

Front View

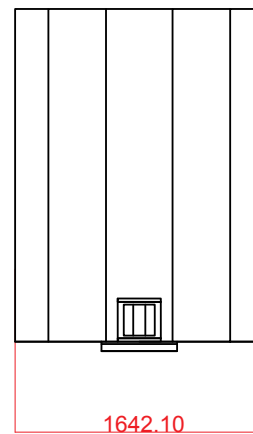

Side View

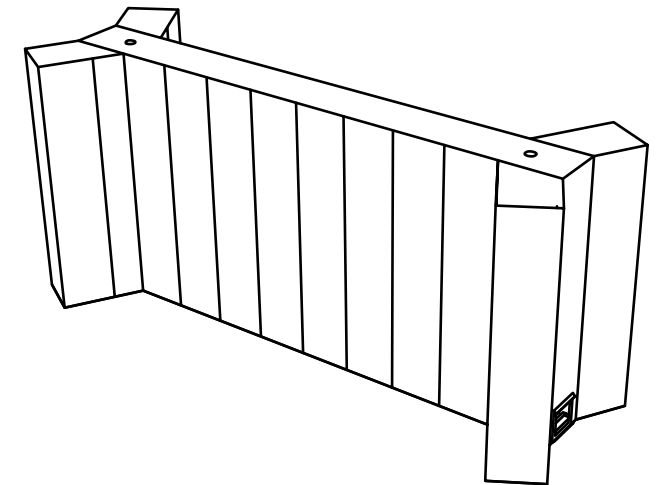

Perspective

General Arrangement Drawings

Bonewall5m

Designed in England | Made in the Future

IS-002-04 Bonewall6m

Core Package

• 1 x Structure, 1 x Packing Bag, 1 x Core 125 Fan, 1 x User Manual

Structure

INFLATED EXTERNAL FOOTPRINT: • 9.6 m²

FABRICS: • FR treated rip-stop nylon.

Power and Fans

FANS: • 1 x Core 125 Fans

POWER DRAWN: • 0.17 amp

FAN DIMENSIONS: • 0.36 m x 0.36 m x 0.36 m (boxed)

NOTE: It is the responsibility of the client (unless agreed otherwise) or site management to ensure that the power used for fans is secure and tested. The above power consumption is for fans only and covers no extra electrical items. No other item should be connected to the fans power lines. Inflate accepts no responsibility for damages to equipment or damages to inflatable structures, injuries to persons, or loss of earnings due to electrical power faults. All fans have 0.3 m 13 amp plug unless otherwise requested. All fans run on 220 Volt standard. For other power levels please consult with Inflate at time of order/enquiry.

Packed Structure

ESTIMATED PACKED SIZE: • 1 x Packing Bag of 0.7 m x 0.6 m x 0.5 m

STRUCTURE WEIGHT: • Gross 10 Kgs

FAN WEIGHT: • 3 kgs

TOTAL WEIGHT: • 13 kgs + package

Installation and Derig

CREW: • min. 1 person

SET UP TIME: • From 5 mins

INFLATION TIME: • 3 mins for structure when fixed

DERIG TIME: • From 5 mins

NOTE: The above refers to setting up the structures and inflation only. Minimums given are to achieve secure installation. Times may vary due to on site location factors, lack of access and other elements outside of Inflates control. Inflate accepts no responsibility for damages to equipment or damages to inflatable structures, injuries to persons, or loss of earnings due to incorrect structure installation method.

NOTE: Please refer to attached technical drawings for specific details on structure and accessory positions. Please note this information is given as guidance only. Inflate accept no responsibility for variations in dimensions or weights.

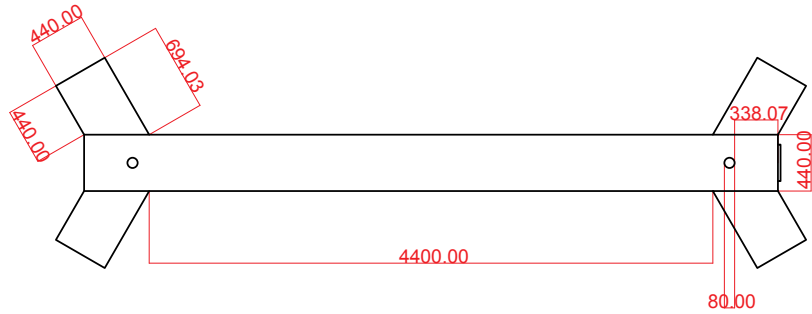

Plan View

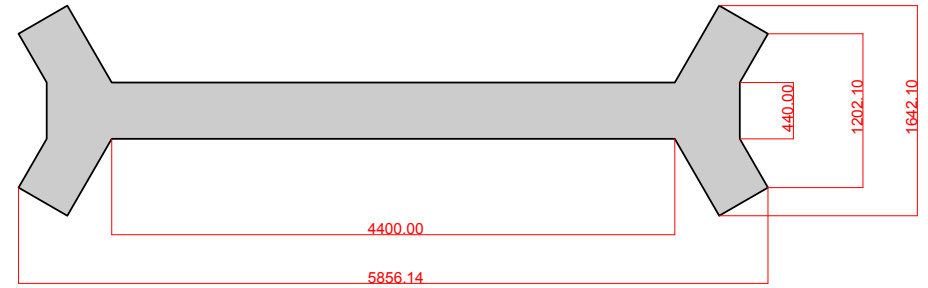

Footprint

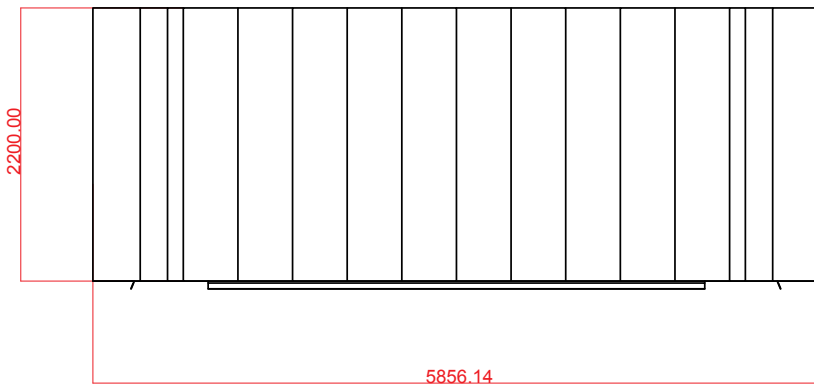

Front View

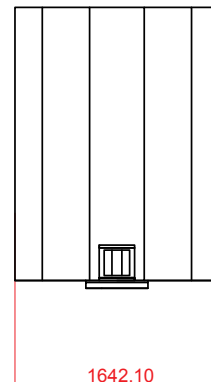

Side View

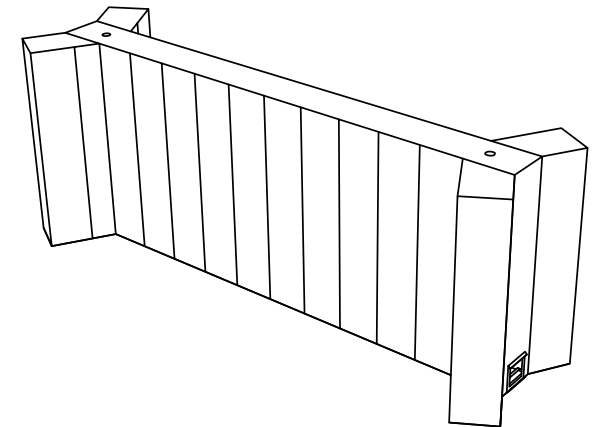

Perspective

General Arrangement Drawings

Bonewall6m

Designed in England | Made in the Future